



DATASHEET APHSPXX(-X) Specification v0.22

Single & Multi-Channel High Performance Sources

1 kHz to 12.75, 20, 40 and 51 GHz



CONTENTS

Definitions	2
Introduction	2
Facts, Figures & Specifications	3
Signal Specifications	3
Frequency Reference	3
Spectral Purity	4
RMS Jitter	4
Level Performance.....	8
Modulation Capabilities	11
Sweeping Capability	13
Trigger (TRIG IN)	13
Multi-Purpose Output (FUNC OUT).....	13
Connectors	14
Mechanical Specifications	16
Ordering Information	17
General Characteristics	18
Notes	20

DEFINITIONS

- The specifications in the following pages describe the warranted performance of the instrument for 23 ± 5 °C after a 30-minute warm-up period

Typical: Expected mean values, not warranted performance

Min and max: Parameter range that is guaranteed by product design, and/or production tested. Warranted performance specifications include guard-bands to account for the expected statistical performance distribution, measurement uncertainties, and changes in performance due to environmental conditions.

INTRODUCTION

- The APHSPXX is a series of phase-coherent, single or multi-channel, ultra-fast switching and ultra-low phase noise signal generators with a frequency range from 1 kHz to 20, 40, and 51 GHz. It is ideally suited for a wide range of applications, where good signal quality, accurate and wide output power ranges, and very stable phase coherence among all channels are required. Outstanding phase noise is combined with good spurious, harmonic rejection and leading-edge switching speed of 5 μ s.

A high-stability OCXO reference provides excellent frequency accuracy and stability. The generator accepts a wide range of external references including the commonly used 10 and 100 MHz for higher phase synchronization, and a flexible reference choice in the range of 1-250 MHz for those applications with customer- or system-specific reference frequencies. Moreover, the APHSPXX features a pair of ANAPICO-specific high-frequency CLK ports (3 GHz, one input and one output) that enables excellent phase synchronization among the outputs of multiple ANAPICO instruments with similar ports.

The APHSPXX comes in a desktop enclosure (single-channel) or 19 inch 2U (up to 4 channels) rack-mountable module form. It can be intuitively controlled by a PC based GUI Software. Moreover, the instrument offers various communication interfaces like USB, LAN or GPIB. Each interface allows for easy and fast communication using SCPI 1999 command set. Remote control of the instrument can be quickly achieved from any host system. A customer-supplied application programming interface (API) or programming examples for Matlab, Labview, C++ and other commercially available tools make the control implementation very straightforward.

FACTS, FIGURES & SPECIFICATIONS

Signal Specifications

PARAMETER	MIN	TYPICAL	MAX	NOTE
Channels	1		4	
Frequency Ranges				
APHSP12	10 MHz		12.75 GHz	
APHSP20	10 MHz		20 GHz	
APHSP40	10 MHz		40 GHz	
APHSP50	10 MHz		51 GHz	
	1 kHz			Option 1K
Resolution		<0.001 Hz		
Phase Adjustment Range	0 deg		360 deg	individually adjustable per channel
Phase Resolution		0.1 deg		
Switching Time				Frequency >10 MHz after SCPI command received
CW Mode		1.5 ms		
Sweep / List Mode			100 μ s	
		3 μ s	5 μ s	Option FS
Thermal Drift		0.015 dB/°C		

Frequency Reference

PARAMETER	MIN	TYPICAL	MAX	NOTE
Internal Reference Frequency		100 MHz 10 MHz		Option LN(+)
Temperature stability 0 to 50 degC			\pm 100 ppb \pm 20 ppb	Option LN(+)
Aging 1st year			1000 ppb 30 ppb 20 ppb	Option LN Option LN+
Aging per day			5 ppb 0.5 ppb < 0.5 ppb	after 30 days operations Option LN Option LN+
Warm-up time		5 min		
Output of internal reference		1, 5, 10, 20, 25, 50, 100 MHz		REF OUT port, selectable
Output of High Frequency Clock		3 GHz		CLK OUT port high phase synchronous mode
Output power	+10 dBm +5 dBm		+13 dBm +10 dBm	3 GHz 1-100 MHz
Output impedance		50 Ohms		
Phase Lock to External Reference		10, 100 MHz integer MHz	250 MHz	STD or Option LN(+) Option VREF
High Frequency Clock Input (Bypass Internal References)		3 GHz		CLK IN port high phase synchronous mode
Reference input level				
1 to 250 MHz	-10 dBm	0 dBm	+10 dBm	
3 GHz	+10 dBm		+13 dBm	
Lock Range				
LN(+), LN(+)+VREF			\pm 0.3 ppm	
STD, STD+VREF			\pm 1.5 ppm	
Reference Input Impedance		50 Ohms		



Spectral Purity

Absolute SSB Phase Noise in dBc/Hz.

Specified values in plain text, typical values in brackets. CW, level = 20 dBm or maximum available output power, whichever is lower

OFFSET	10 Hz	100 Hz	1 kHz	10 kHz	100 kHz	1 MHz	10 MHz
FREQUENCY							
100 MHz	-100 (-105)	-130 (-135)	-154	-150	-156	-156	-156
1 GHz	-80 (-85)	-110 (-115)	-140 (-142)	-148 (-150)	-150 (-152)	-150 (-153)	-150 (-153)
4 GHz	-68 (-73)	-98 (-103)	-130 (-132)	-140 (-142)	-146(-148)	-147 (-150)	-147 (-150)
10 GHz	-60 (-65)	-90 (-95)	-123 (-125)	-134 (-135)	-138 (-140)	-144 (-145)	-144 (-145)
20 GHz	-54 (-59)	-84 (-89)	-117 (-119)	-128 (-129)	-133 (-134)	-138 (-139)	-138 (-139)
40 GHz	-48 (-53)	-78 (-83)	-111 (-113)	-122 (-123)	-127 (-128)	-132 (-133)	-132 (-133)
50 GHz	-46 (-51)	-76 (-81)	-109 (-111)	-116 (-121)	-125 (-126)	-130 (-131)	-130 (-131)

Absolute SSB Phase Noise with LN(+)² Option in dBc/Hz

Specified values in plain text, typical values in brackets. CW, level = 20 dBm or maximum available output power, whichever is lower

OFFSET	10 Hz	100 Hz	1 kHz	10 kHz	100 kHz	1 MHz	10 MHz
FREQUENCY							
100 MHz	-120 (-123)	-130 (-135)	-154	-150	-156	-156	-156
1 GHz	-100 (-103)	-110 (-115)	-140 (-142)	-148 (-150)	-150 (-152)	-150 (-153)	-150 (-153)
4 GHz	-88 (-91)	-98 (-103)	-130 (-132)	-140 (-142)	-146(-148)	-147 (-150)	-147 (-150)
10 GHz	-80 (-83)	-90 (-95)	-123 (-125)	-134 (-135)	-138 (-140)	-144 (-145)	-144 (-145)
20 GHz	-74 (-77)	-84 (-89)	-117 (-119)	-128 (-129)	-133 (-134)	-138 (-139)	-138 (-139)
40 GHz	-68 (-71)	-78 (-83)	-111 (-113)	-122 (-123)	-127 (-128)	-132 (-133)	-132 (-133)
50 GHz	-66 (-69)	-76 (-81)	-109 (-111)	-116 (-121)	-125 (-126)	-130 (-131)	-130 (-131)

Harmonics, Subharmonics, Non-harmonics

PARAMETER	MIN	TYPICAL	MAX	NOTE
Harmonics				at +10 dBm output power
1 kHz to 350 MHz		-35 dBc	-30 dBc	
350 MHz to 8 GHz		-60 dBc	-50 dBc	
8 GHz to 22 GHz		-65 dBc	-55 dBc	
22 GHz to 30 GHz		-25 dBc	-20 dBc	
30 GHz to 51 GHz		-60 dBc	-50 dBc	
Sub-Harmonics				at +10 dBm output power
1 kHz to 350 MHz		-80 dBc		
350 MHz to 12.75 GHz		-75 dBc	-65 dBc	Incl. high-order subharmonics
12.75 GHz to 51 GHz		-70 dBc	-50 dBc	
Non-Harmonic Spurious				10 kHz to 0.5 GHz offset from carrier
1 kHz to 350 MHz		-90	-80	
350 MHz to 4.5 GHz		-85	-80	
4.5 GHz to 12.75 GHz		-80	-75	
12.75 GHz to 25.5 GHz		-75	-70	
25.5 GHz to 51 GHz		-70	-65	



RMS Jitter

CARRIER FREQUENCY	MIN	TYPICAL	MAX	NOTE
155 MHz		11 fs	15 fs	BW 100 Hz to 1.5 MHz
622 MHz		8.5 fs	10 fs	BW 1 kHz to 5 MHz
1 GHz		15fs	20 fs	BW 10 Hz to 10 MHz
2.488 GHz		8.5 fs	10 fs	BW 5 kHz to 20 MHz
9.952 GHz		8.5 fs	10 fs	BW 10 kHz to 80 MHz

Figure 1: Phase noise at different frequencies. Option LN(+). (20 dBm or maximum power whichever is lower)

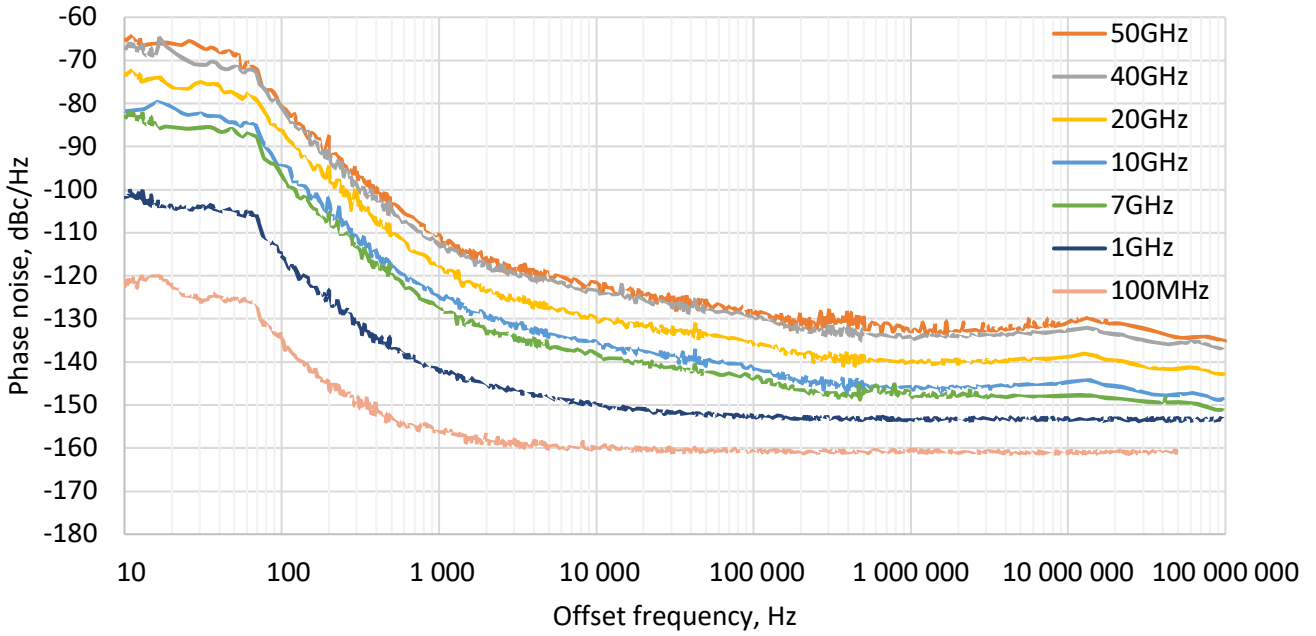

Figure 2: 3 GHz CLK out signal phase noise. Option LN(+)

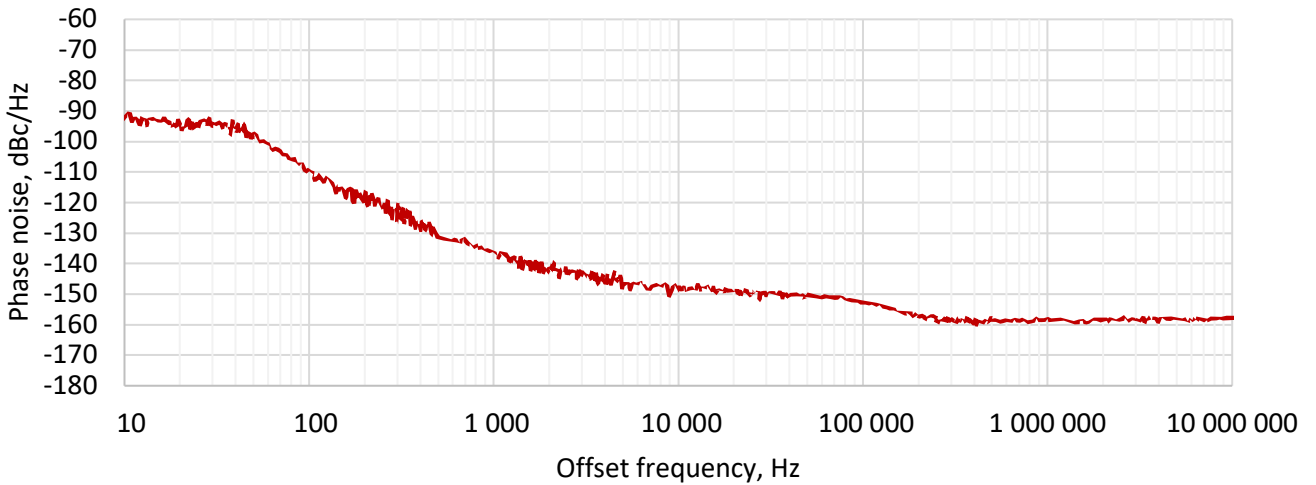

Figure 3: Amplitude noise at different frequencies. Power level +10 dBm

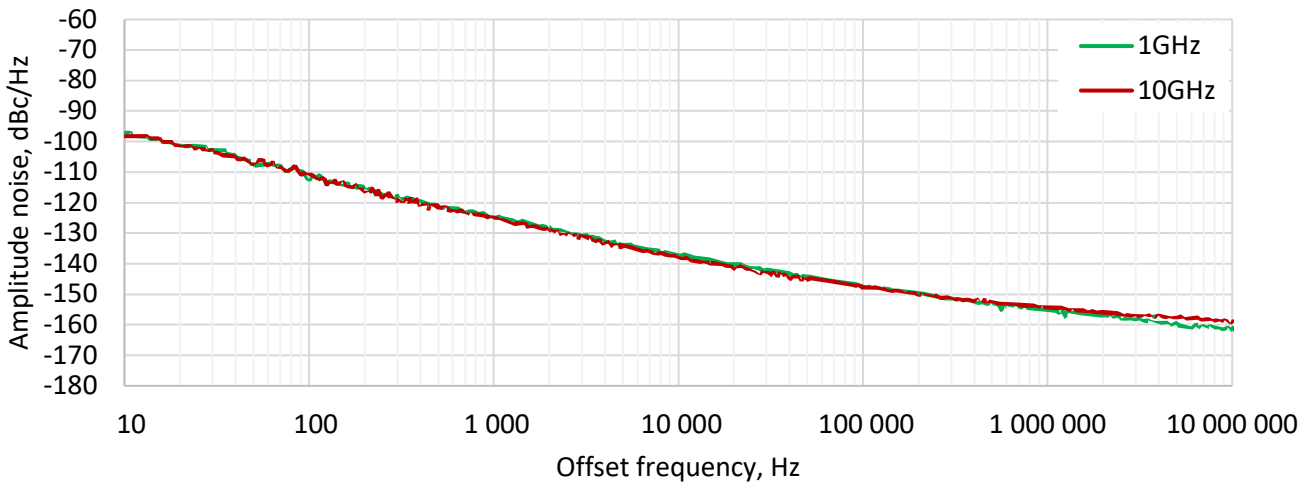

Figure 4: F/2 Subharmonic levels at different output power levels (20 dBm or maximum power whichever is lower) (tba)

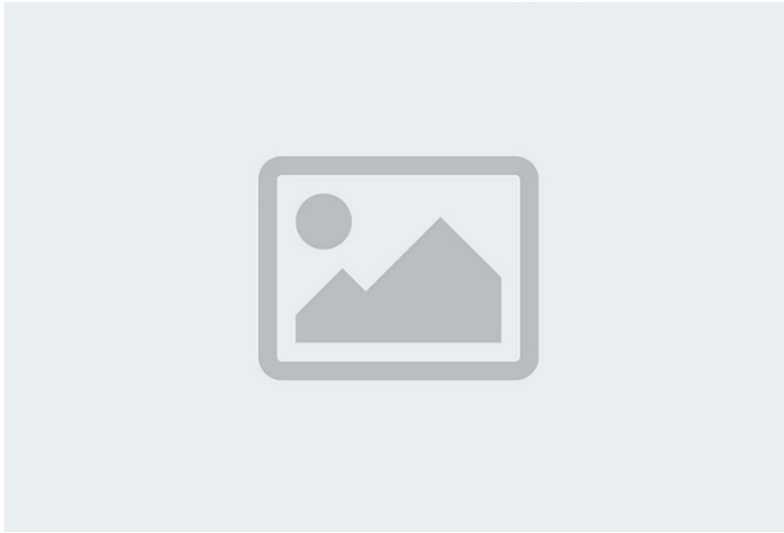

Figure 5: 2nd harmonic levels at different output power levels (20 dBm or maximum power whichever is lower)

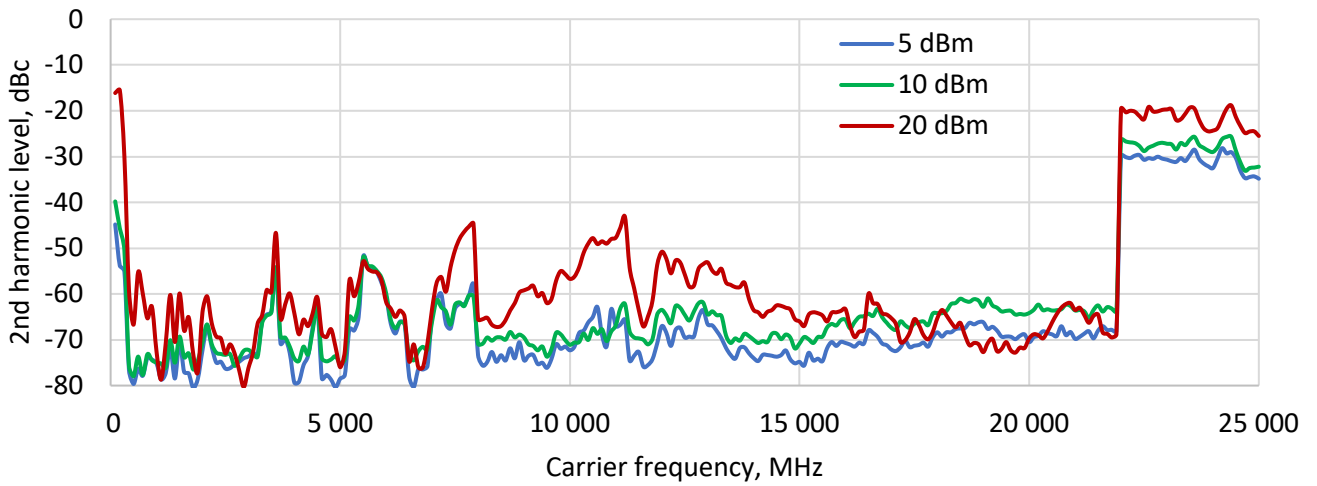

Figure 6: 3rd harmonic levels at different output power levels (20 dBm or maximum power whichever is lower)

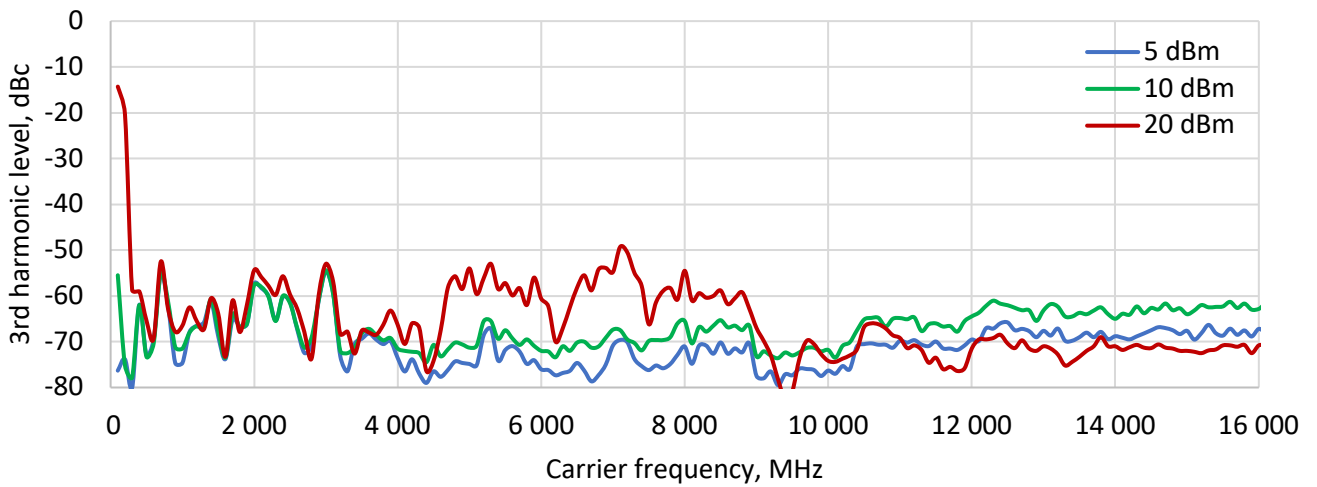

Figure 7: Channel-to-channel isolation (tba)

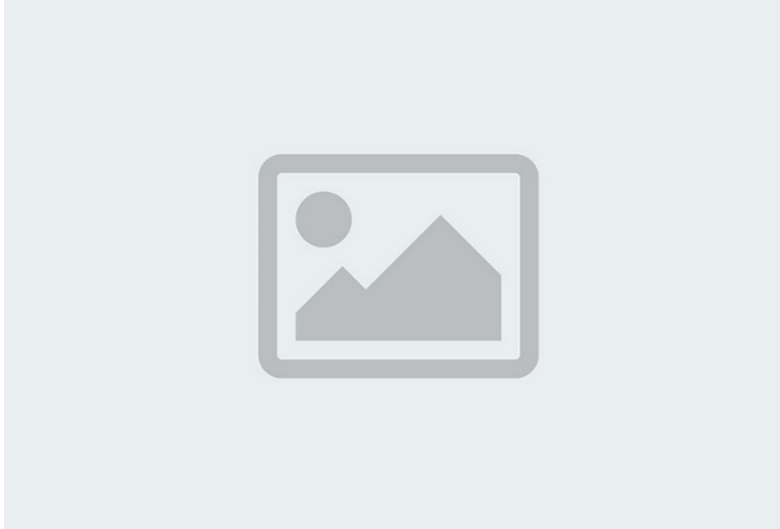
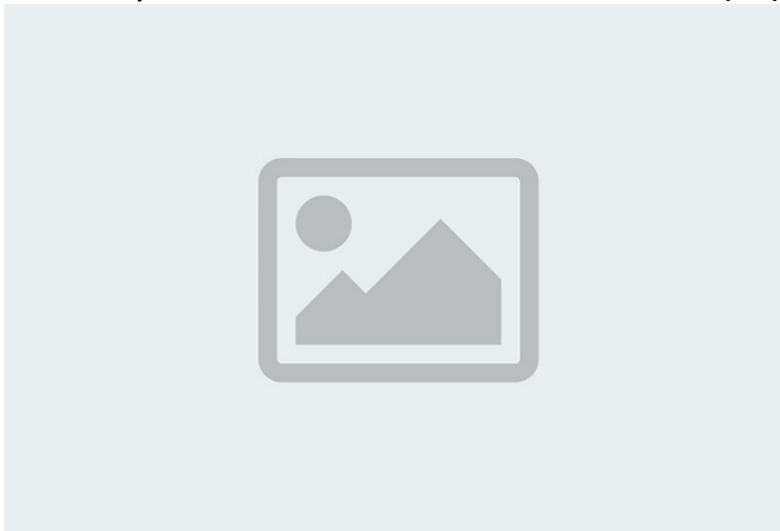

Figure 8: Relative channel-to-channel phase stability. Measured at TBD GHz, 10 dBm output in temperature-controlled environment over 10 hours (tba)





Level Performance

PARAMETER	MIN	TYPICAL	MAX	NOTE
Output Power Level				
1 kHz to 1 MHz	-20 dBm		+10 dBm	
1 MHz to 10 MHz	-20 dBm		+12 dBm	
10 MHz to 2.5 GHz	-20 dBm		+18 dBm	
2.5 GHz to 44 GHz	-20 dBm		+19 dBm	
44 GHz to 51 GHz	-20 dBm		+15 dBm	
Output Power Level				Option PE2-12/20/40
1 kHz to 1 MHz	-120 dBm		+10 dBm	
1 MHz to 10 MHz	-120 dBm		+12 dBm	
10 MHz to 2.5 GHz	-120 dBm		+16 dBm	
2.5 GHz to 44 GHz	-120 dBm		+18 dBm	
Output Power Level				Option PE2-50
1 kHz to 1 MHz	-110 dBm		+10 dBm	
1 MHz to 10 MHz	-110 dBm		+12 dBm	
10 MHz to 2.5 GHz	-110 dBm		+16 dBm	
2.5 GHz to 44 GHz	-110 dBm		+18 dBm	
44 GHz to 51 GHz	-110 dBm		+12 dBm	
Power Resolution		0.01 dB		
Reverse Power Protection				
DC Voltage			0 V	
RF Power			26 dBm	
Output impedance		50 Ohms		
VSWR		1.3	1.5	< 15 GHz
		1.6	1.8	15 to 35 GHz
		1.9	2.2	> 35 GHz

Power Level Error

Specified values in plain text, typical values in brackets.

FREQUENCY RANGE	-110 to -50 dBm Option PE2	-50 to -15 dBm Option PE2	-15 to +15 dBm	+ 15 dBm to Max Power
1 kHz to 10 MHz	2.0 dB	1.2 dB	1 dB (0.5 dB)	1.3 dB
10 MHz to 1 GHz	2.0 dB	1.3 dB	0.8 dB (0.15 dB)	1.3 dB
1 to 22 GHz	2.0 dB	1.8 dB	0.5 dB (0.2 dB)	2.0 dB
22 to 42 GHz	2.3 dB	2.0 dB	1.2 dB (0.4 dB)	2.0 dB
42 to 51 GHz	2.5 dB	2.0 dB	1.3 dB (0.4 dB)	2.5 dB

Relative Power Level Error (0.1 dB step)

Specified values in plain text, typical values in brackets.

FREQUENCY RANGE	-110 to -50 dBm Option PE2	-50 to -15 dBm Option PE2/PE4	-15 to +15 dBm	+ 15 dBm to Max Power
1 kHz to 10 MHz	(< 0.1 dB)	0.5 dB (< 0.1 dB)	0.5 dB (< 0.1 dB)	(< 0.1 dB)
10 MHz to 1 GHz	(< 0.1 dB)	(< 0.1 dB)	(< 0.1 dB)	(< 0.1 dB)
1 to 51 GHz	(< 0.1 dB)	(< 0.1 dB)	(< 0.1 dB)	(< 0.1 dB)

Figure 9: Maximum power level statistics over 20 devices

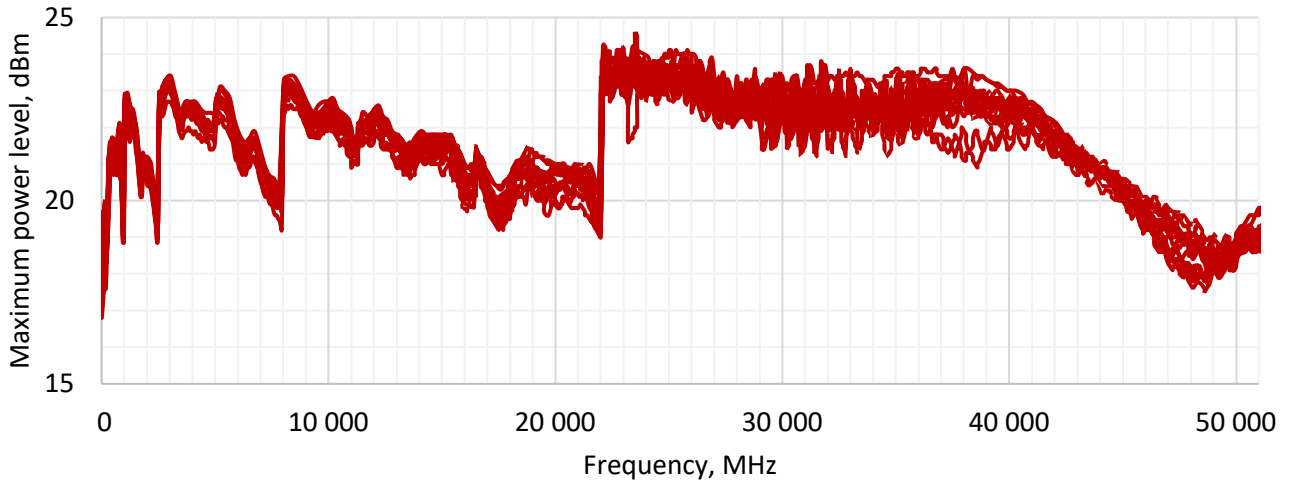

Figure 10: LF maximum power level

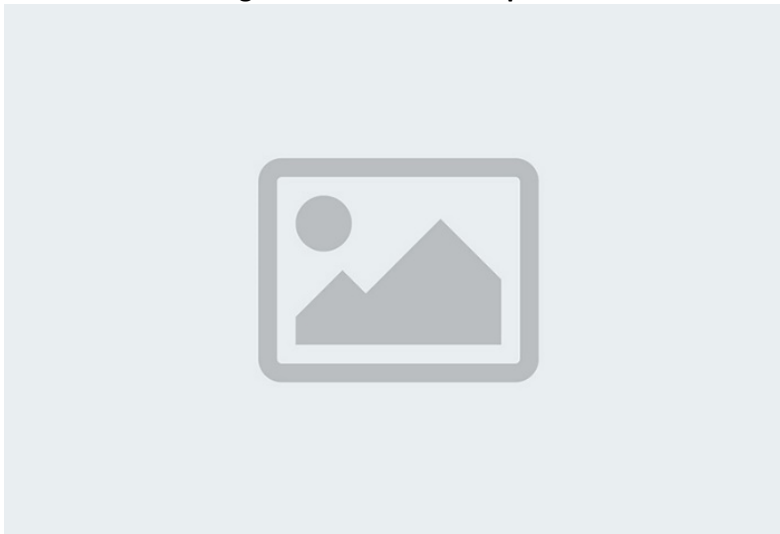

Figure 11: Power level error between -15 and +15 dBm over frequency

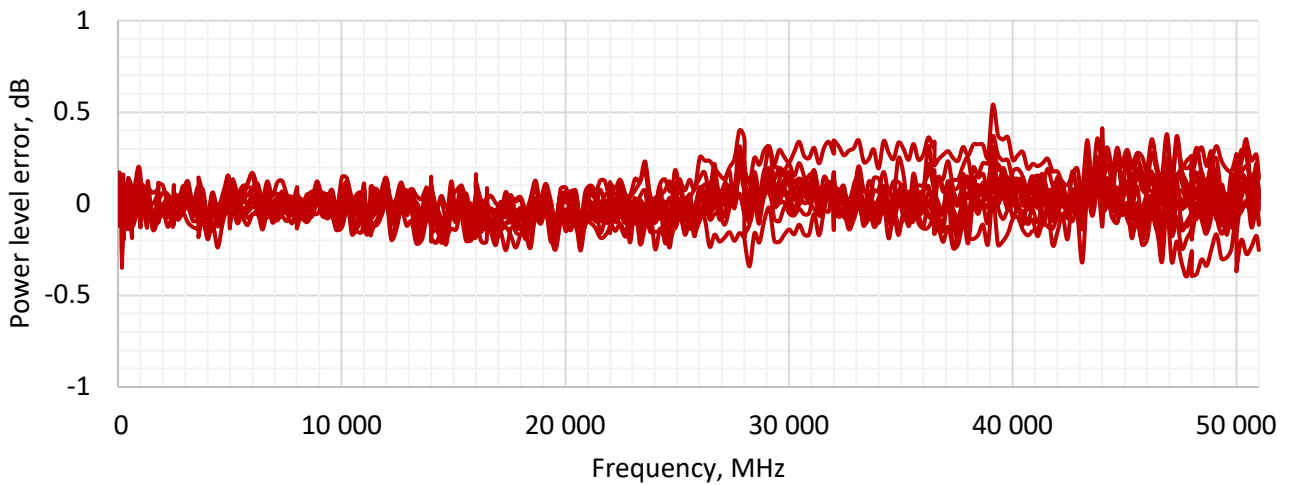

Figure 12: Absolute power level error at different frequencies

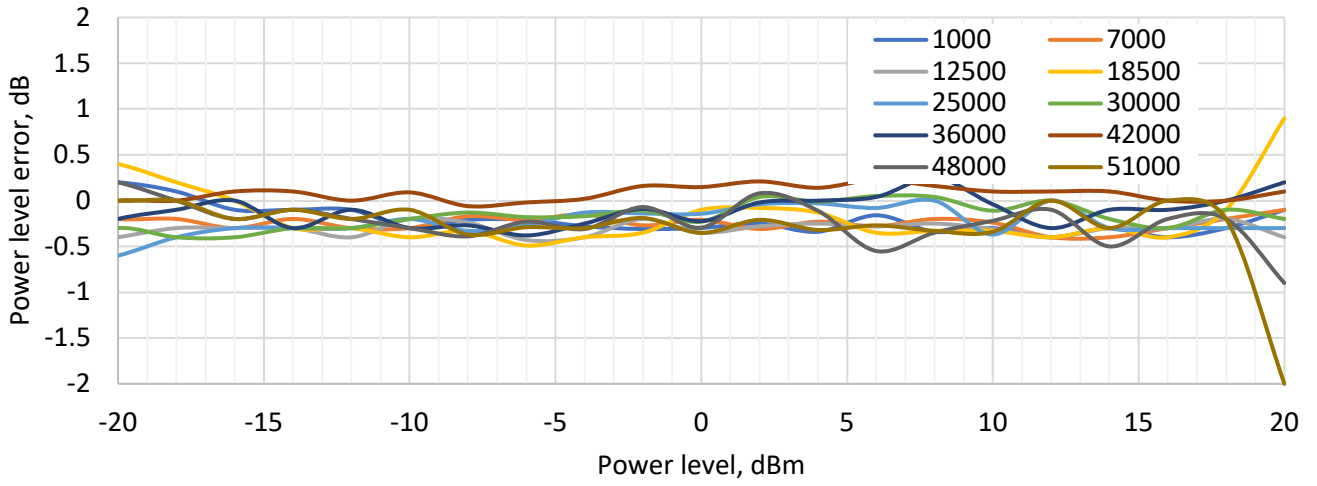
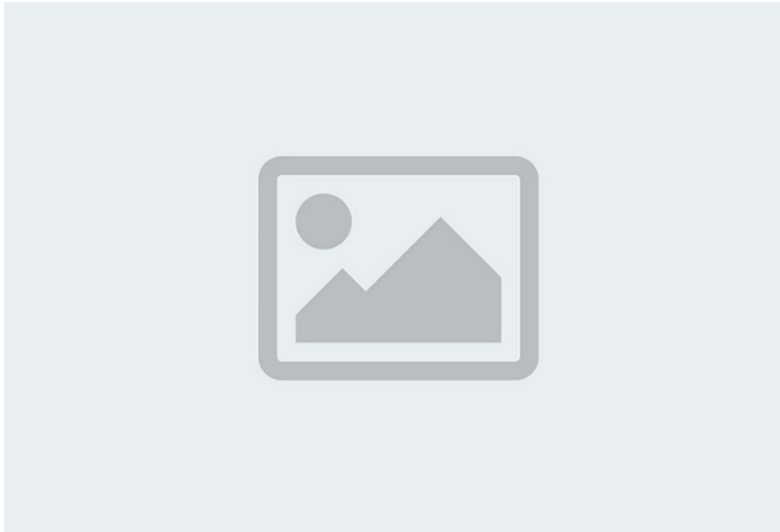

Figure 13: Relative power level error in 0.1 dB step at 51 GHz. Option PE2 (tba)





Modulation Capabilities

PARAMETER	MIN	TYPICAL	MAX	NOTE
Pulse Modulation				Option Pulse
Modulation Source		Internal/ External		
External input amplitude	TTL			
Pulse rise/fall time		3 ns	5 ns	
On/off ratio (power >= +5 dBm)	80 dB	95 dB		
Pulse overshoot			10%	
Pulse delay		20 ns		
Pulse polarity		Normal, inverse		selectable
Internal Pulse Generator				
Repetition frequency (PRF)	0.1 Hz		50 MHz	= 1/T
Duty cycle	1 % to 99 % in 1% steps			within specified minimum pulse width
Pulse Pattern Modulation & Staggered PRF				using internal pattern generator
Pulse width	10 ns		20 s	
Programmable pattern length	2		65536	
Duty cycle	0.05%		99.95%	
Pulse width resolution		5 ns		
Pulse period (T) accuracy		$5 \cdot 10^{-6} \cdot T + 3\text{ns}$		
Pulse width accuracy		$5 \cdot 10^{-6} \cdot T + 5\text{ns}$		
Pulse jitter		2 ns	5 ns	
Polarity		selectable		
Amplitude Modulation				Option MOD
Modulation Source				
Modulation Depth	0		100%	
Depth accuracy			$0.05 \cdot \text{Depth} + 2$	
Depth resolution		1%		
Distortion (THD)			3%	
Modulation rate	DC		30 kHz	
Modulation waveforms				
Frequency Modulation				Option MOD
Modulation source				
Maximum Frequency deviation (peak)			N·5 MHz	
Deviation accuracy			$0.01 \cdot \text{Dev} + 2\text{Hz}$	
Distortion (THD)			3%	
Modulation rate	DC		30 kHz	
Modulation waveforms				
Phase Modulation				Option MOD
Modulation Source				
Phase deviation (peak)			N·100 rad	
Deviation accuracy			$0.01 \cdot \text{Dev} + 1\text{mrad}$	
Modulation rate	DC		30 kHz	
Distortion (THD)			3%	
Modulation waveforms				

Output frequency	N value
1kHz to <350 MHz	1
350 to <562.5 MHz	1/16
562.5 to <1125 MHz	1/8
1.125 to <2.25 GHz	1/4
2.25 to <4.5 GHz	1/2
4.5 to <12.75 GHz	1
12.75 to <25.5 GHz	2
25.5 to 51 GHz	4

Figure 14: PULM On/Off ratio over frequency at different output power levels (20 dBm or maximum power whichever is lower)

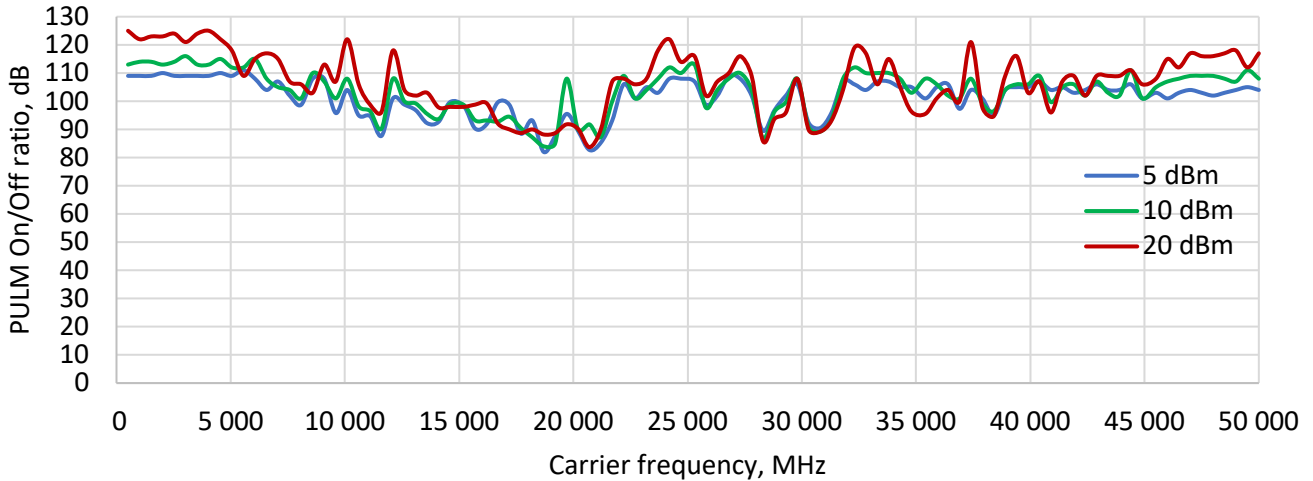

Figure 15: 10 GHz pulse-modulated signal

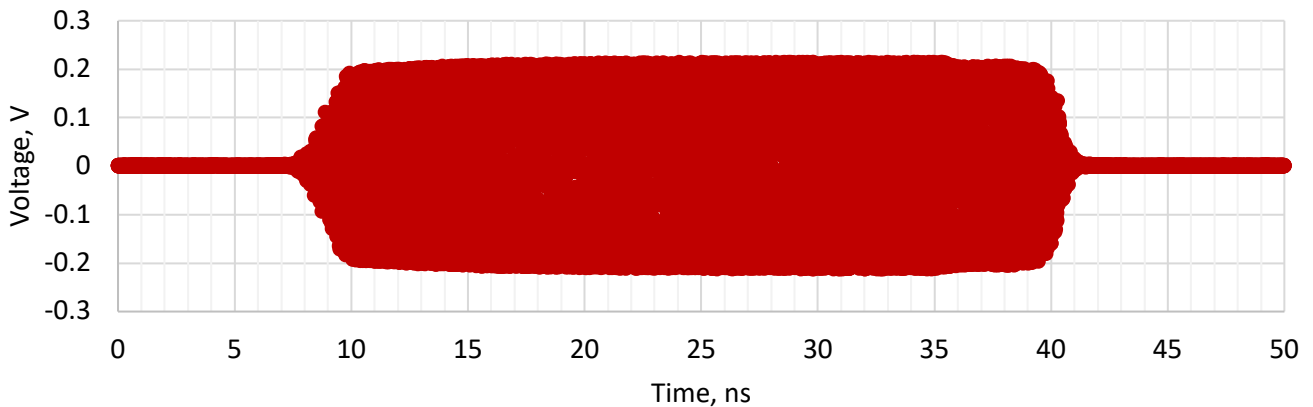
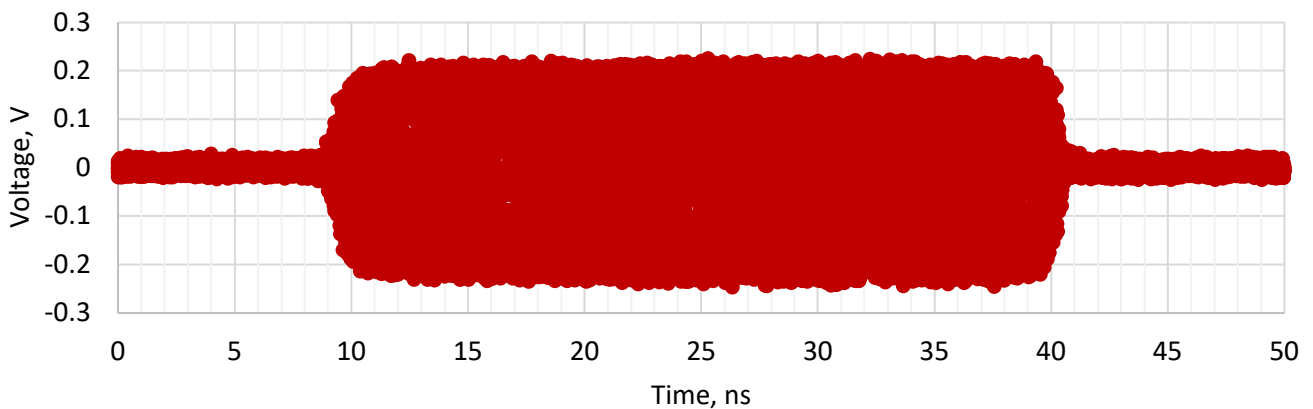

Figure 16: 50 GHz pulse-modulated signal



Sweeping Capability

PARAMETER	MIN	TYPICAL	MAX	NOTE
Sweep Parameters	Frequency, power, phase, list			
Sweep Type	Linear, logarithmic, random			
Step time ($t_{step} = t_{dwell} + t_{off}$)	500 μ s 5 μ s		19998 s 19998 s	Option FS
Dwell time (t_{dwell})	0 μ s		9999 s	
Off time (t_{off})	0 μ s		9999 s	
Time resolution		5 ns		
Timing delay (τ_{de})		50 ns		
Transient time (τ_{inv})			5 μ s	
Timing accuracy per point		5 ns		
Number of points	2		10000	Per channel

Trigger (TRIG IN)

PARAMETER	MIN	TYPICAL	MAX	NOTE
Trigger Types	Continuous, Single (point), Gated, Gated direction			
Trigger Source	External, Bus (LAN, USB)			
Trigger Modes	Continuous free run, Trigger and run, Reset and run			
Trigger latency		5 ns		
Trigger uncertainty		10 ns		
External trigger delay	50 ns		40 s	settable
External delay resolution		5 ns		
Trigger Modulo	1		255	execute only on Nth trigger event
Trigger Polarity	Rising, Falling			
External trigger input threshold	0.85 V	0.9 V	0.95 V	TTL compatible
External trigger input voltage range	-0.5 V		+5.5 V	TTL compatible
External trigger input hysteresis		60 mV		

Multi-Purpose Output (FUNC OUT)

PARAMETER	MIN	TYPICAL	MAX	NOTE
PULM VIDEO OUTPUT				
Output		CMOS		
Period	30 ns		50 s	
Pulse width	15 ns		50 s	
RF delay		10 ns		
TRIGGER OUT Synchronization Mode for Multiple Sources				
Modes	Trigger on sweep start Trigger on each point Signal Valid			

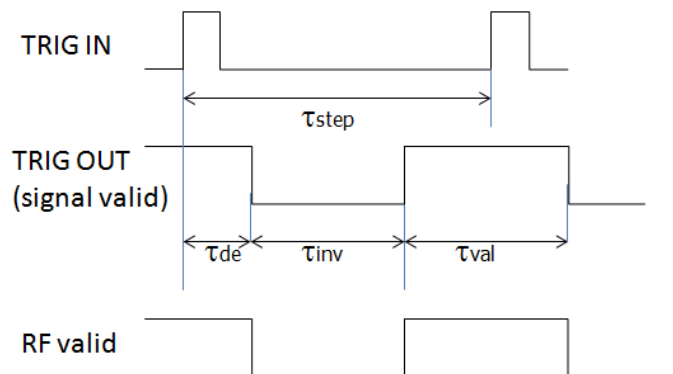

CONNECTORS

Single-Channel Front Panel (Desktop enclosure)

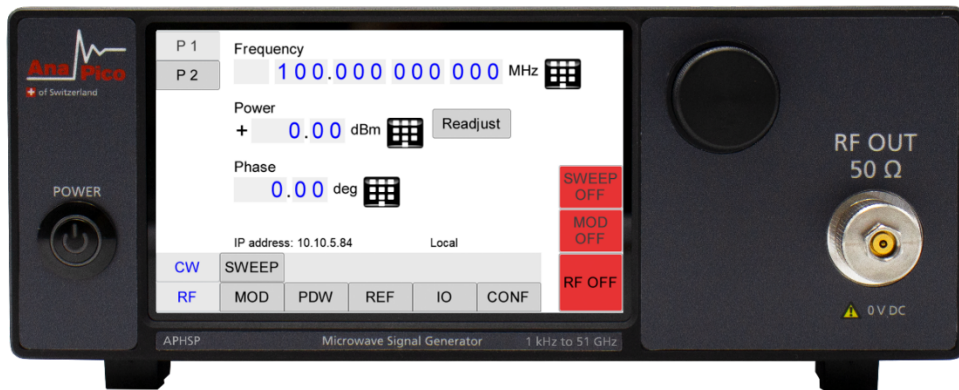

- Power switch
- Rotary knob
- RF Outputs:
 - APHSP12/20: 3.5mm male hand-tight (female flange-mount optional)
 - APHSP40: 2.92 mm male hand-tight (female flange-mount optional)
 - APHSP50: 1.85/2.4 mm male hand-tight (female flange-mount optional)

Single-Channel Rear Panel (Desktop enclosure)

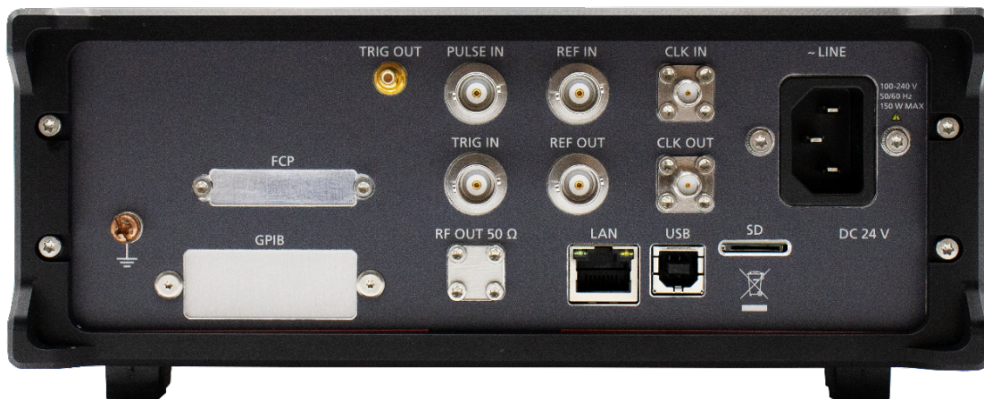

- Trigger output (TRIG OUT): BNC female
- PULSE IN: Pulse modulation input: BNC female
- Reference input (REF IN): BNC female
- High Stability Reference input (CLK IN, 3 GHz): SMA female
- Trigger input (TRIG IN): BNC female
- Reference output (REF OUT): BNC female
- High Stability Reference output (CLK OUT, 3 GHz): SMA female
- GPIB: IEEE-488.2, 1987 with listen and talk (optional)
- LAN connection: RJ-45
- USB 2.0 device
- Card slot (SD)
- 100-240V AC power plug
- Ground reference screw (earth) M4

Multi-Channel Front Panel (19" 2 HU)

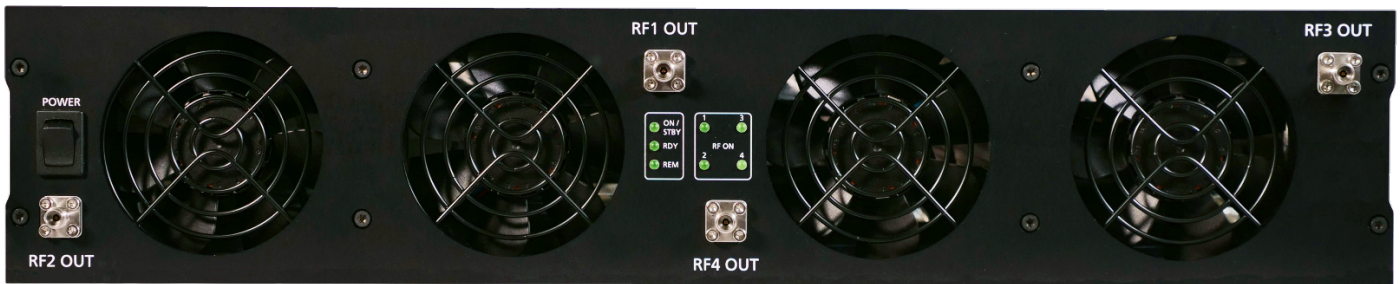

- RF outputs:
 - APHSP12/20: SMA female
 - APHSP40: 2.92 mm female
 - APHSP50: 1.85/2.4 mm female

Multi-Channel Rear Panel (19" 2 HU)

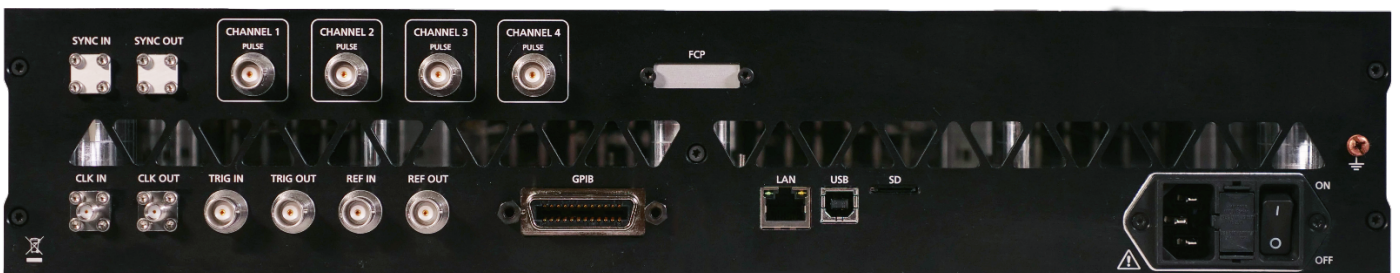

- Unit-to-unit synchronization signal input (SYNC IN): SMA female
- Unit-to-unit synchronization signal output (SYNC OUT): SMA female
- Channel 1, 2, 3, 4 PULM input: BNC female
- Fast control port (FCP): 36-pin mini-D female 3M MDR 102 series
- High Stability Reference input (CLK IN, 3 GHz): SMA female
- High Stability Reference output (CLK OUT, 3 GHz): SMA female
- Trigger input (TRIG IN): BNC female
- Trigger output (TRIG OUT): BNC female
- Reference input (REF IN): BNC female
- Reference output (REF OUT): BNC female
- GPIB: IEEE-488.2, 1987 with listen and talk (optional)
- LAN connection: RJ-45
- USB 2.0 device
- Card slot (SD)
- FUSE (3.15 A)
- 100-240V AC power plug
- Power switch
- Ground reference screw (earth) M4

MECHANICAL SPECIFICATIONS

Desktop enclosure: Dimensions & Weight

Including connectors	W x L x H = 232 x 393 x 96.75 mm [9.1 x 15.5 x 3.8 in], ≤10 kg [22 lbs]
----------------------	---

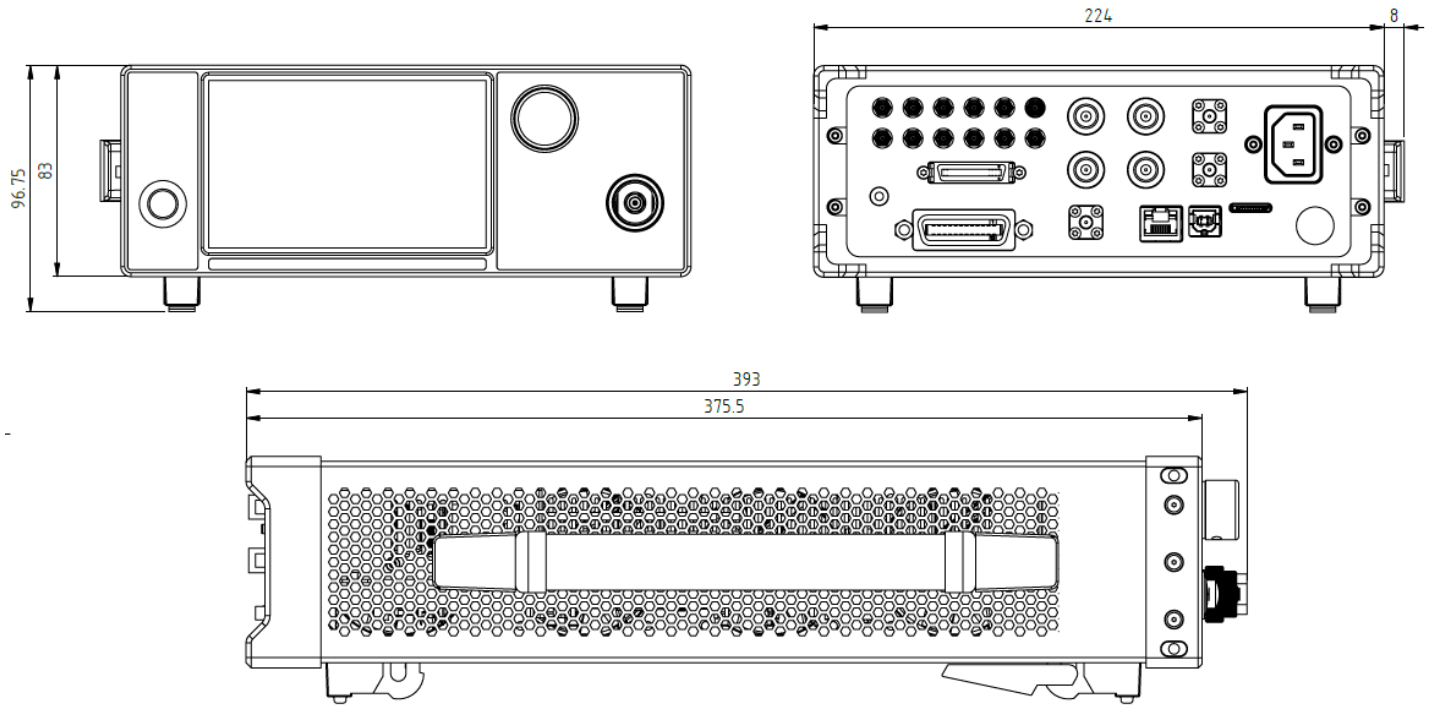

19" 2HU: Dimensions & Weight

Including connectors	W x L x H = 444 x 594 x 88 mm [17.5 x 23.4 x 3.5 in], 18 kg [39.7 lbs]
----------------------	--

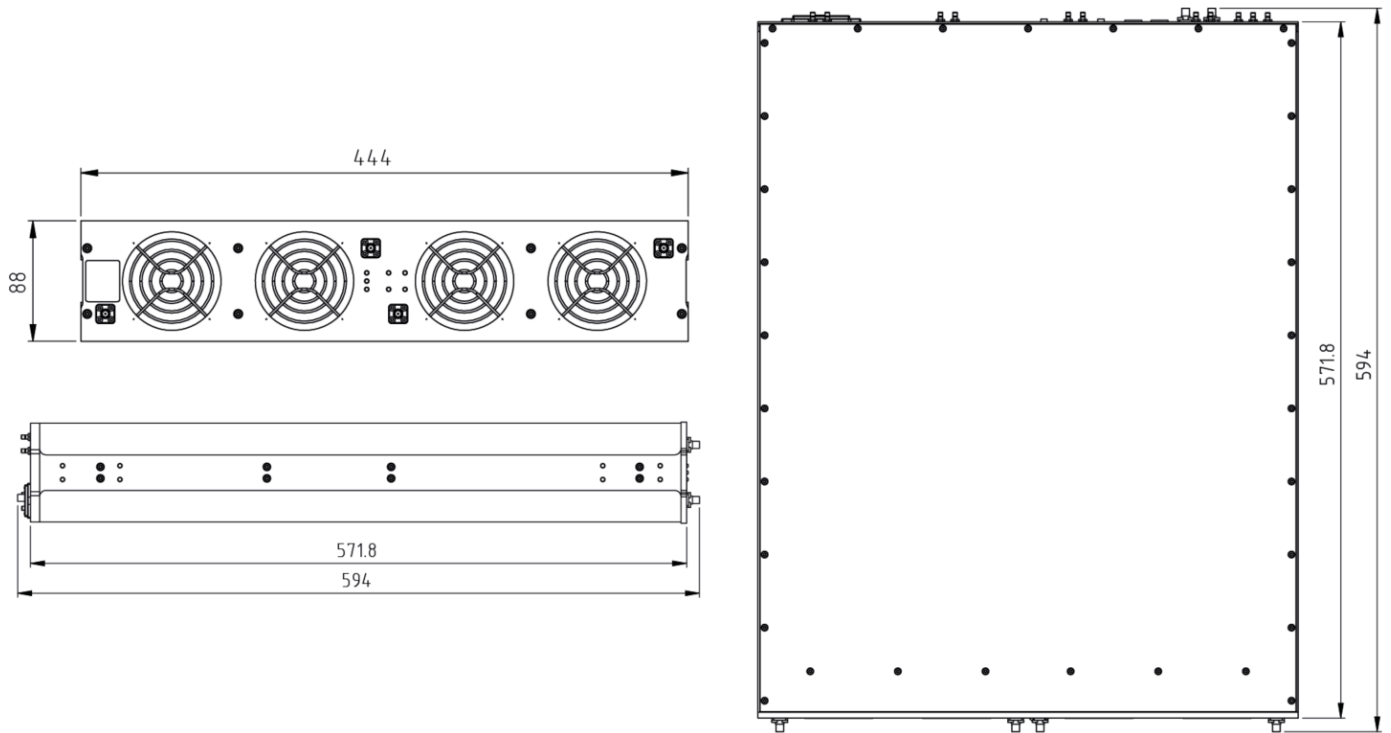

ORDERING INFORMATION



Host Model No.	Product	Description
APHSP	APHSP12	High performance signal generator up to 12.75 GHz
APHSP	APHSP20	High performance signal generator up to 20 GHz
APHSP	APHSP40	High performance signal generator up to 40 GHz
APHSP	APHSP50	High performance signal generator up to 51 GHz
APHSPXX-X	APHSPXX-1	1-channel signal generator, 19" 1HU rack-mount module
APHSPXX-X	APHSPXX-2	2-channel signal generator, 19" 1HU rack-mount module
APHSPXX-X	APHSPXX-3	3-channel signal generator, 19" 1HU rack-mount module
APHSPXX-X	APHSPXX-4	4-channel signal generator, 19" 1HU rack-mount module
APHSPXX-X	Option FS	Ultra-fast frequency/power switching
APHSPXX-X	Option 1K	Frequency range extension to 1 kHz
APHSPXX-X	Option LN	Enhanced close in phase noise and frequency stability
APHSPXX-X	Option LN+	Option LN with improved long term frequency stability
APHSPXX-X	Option VREF	External reference frequency in range 1 to 250 MHz
APHSPXX-X	Option MOD	Analog modulations
APHSPXX-X	Option PULSE	Pulse modulation
APHSPXX-X	Option PE2-12/20/40	Mechanical step attenuator down to -120dBm for 12, 20 and 40 GHz models
APHSPXX-X	Option PE2-50	Mechanical step attenuator down to -110dBm for 51 GHz model
APHSPXX-X	Option ReCal	Recalibration with test data (recommended: 2 years interval)
APHSPXX-X	Option WE	One-year warranty extension (standard: 2 years)
APHSPXX-X	Option DATA	Commercial Calibration Certificate with test data (per channel)
APHSPXX-X	Option FLASH	MicroSD card slot for removable SD memory
APHSPXX-X	Option GPIB	GPIB interface

GENERAL CHARACTERISTICS

Remote programming interfaces:

- Gbit Ethernet interface
- USB 2.0 device
- GPIB (IEEE-488.2,1987) with listen and talk (Option GPIB)
- Control Language SCPI Version 1999.0

Power requirements: 100 - 240 VAC, 50 or 60 Hz, <170W (rack mount, 50W + 30W per channel), <100W (desktop)

Operating ambient temperature range: 0 to +50 °C

Storage ambient temperature range: -40 to +70 °C

Relative humidity range: 20 to 85 %RH (desktop models), 20 to 90 %RH (rack mount models)

Operating and storage altitude up to 15,000 feet/4600 m

Environmental: Levels similar to MIL-PRF-28800F Class 3/4



Safety / EMC comply with applicable Safety and EMC regulations and directives.

Weight:

Multi-Channel: 19" 2HU HI enclosure 18 kg [39.7 lbs]

Single-Channel: Desktop enclosure ≤10 kg [22 lbs]

Dimensions:

Multi-Channel: 19" 2HU HI enclosure W x L x H = 444 x 594 x 88 mm [17.5 x 23.4 x 3.5 in]

Single-Channel: Desktop enclosure W x L x H = 232 x 393 x 96.75 mm [9.1 x 15.5 x 3.8 in]

 **Document History**

Version	Date	Author	Notes
V000	2023-06-27	AG	First release
V010	2024-01-16	AG	Preliminary specs and plots added for: Maxpower, Harmonics, Subharmonics, PULM. Options list updated. APHSP12 added.
V011	2024-01-17	AG	Changed power level uncertainties. Changed harmonics specs for 22-30 GHz. Updated tables formatting. Updated sweep specs.
V012	2024-01-18	AG	Updated power consumption
V013	2024-01-24	AG	Changed harmonics plot colors, changed power error plot limits, changed pulse-modulated plot from 1 to 10 GHz, updated pulse width for PULM
V014	2024-02-20	AG	Updated harmonics/subharmonics specs. Harmonics and subharmonics plots updated/added. PULM specs updated. PULM on/off plots added. AM noise plots added. Updated PhN plot and specs. Added spur specs. Updated subharm. spec.
V015	2024-02-21	AG	Jitter specs, CLK output phase noise plot added
V016	2024-03-14	EE	Added mechanical specs
V017	2024-04-03	AG	Updated MOD parameters. Updated output connectors descriptions. Updated maxpower specs. Updated Refout power specs. Updated harmonics plots.
V018	2024-05-17	AG	Updated harmonics, PULM On/Off ratio plots, MOD, Maxpower specs
V019	2024-06-21	AG	Updated PE2 power level specs
V020	2024-08-13	SH	Added temperature, humidity and altitude specifications
V021	2024-10-09	SH	Address change, desktop power requirement
V022	2024-10-04	AG	Changes of PhN specs

AnaPico of Switzerland

Feldeggstrasse 5
8152 Glattbrugg
Switzerland

Phone +41 44 440 00 50
Email sales@anapico.com

www.anapico.com
www.anapico.com/downloads/

